



Tantalum and OxiCap[®] niobium oxide capacitors deliver enhanced reliability, wide temp range and low leakage for automotive applications

The automotive industry is a fast-developing sector driven by customer demands concerning comfort, safety or increased functionality. Many different electronic systems are now accommodated in modern cars and many of them directly influence the reliability of the car and safety of the passengers. This, in turn, means that electronic components used in key electronic systems must also be very reliable. Capacitors are used in many automotive electronic systems and their quality, stability and reliability has been rigorously analyzed by automotive producers.



If we compare tantalum and niobium oxide (OxiCap[®]) products with other capacitor technologies we can observe significant benefits.

Versus aluminium electrolytic capacitors

Unlike aluminium electrolytic capacitors, tantalum and OxiCap capacitors do not exhibit effects due to drying-out therefore they have stable electrical parameters (capacitance, ESR, leakage current, etc.) over time, so functionality remains unaffected with time.

Versus multilayer ceramic chip capacitors

Tantalum and OxiCap capacitors do not exhibit any piezo effect, which generates unwelcome additional noise in MLCCs. Another advantage that tantalums and niobium oxide devices have is better stability of parameters over temperature and applied DC bias. Broad frequency coupling requires a high capacitance that remains stable over temperature and applied DC voltage. With no

piezoelectric effect, less capacitance variation over temperature and no voltage dependence, tantalum or OxiCap capacitors are a better fit than MLCC in coupling circuits.

AVX's tantalum and OxiCap niobium oxide capacitors are produced according to automotive quality standard TS16949 and all capacitor series fulfil the technical requirements of standard AEC-Q200 so they are suitable for automotive applications.

Tantalum capacitors in automotive applications

TAJ/TPS are standard reliability series (1%/1000 hours) well suited to general automotive systems. TAJ devices offer standard ESR performance: designers requiring lower ESR levels should choose TPS devices. Products are available with capacitances up to 2200 μ F and rated at up to 50 V; operating temperature range is -55 to 125degC.

AVX developed its TRJ tantalum professional capacitor series for use in demanding environments that call for higher performance under electrical and mechanical stress, and technical improvements were made that strengthen the structure of capacitor and make it more robust in such environments.

There are several main differences between standard reliability TAJ / TPS and TRJ products which result in enhanced reliability (0.5%/1000 hours):

- Well-ried tantalum powders are used to ensure the long-term stability of electrical performance.
- Conservative design rules are followed both in design and manufacturing. Very strict quality control limits are applied and additional testing is performed. 100% hard surge current screening, extended electrical testing and accelerated burn-in process are used to achieve and verify the high robustness of the parts.
- Leakage current is reduced to 75% that of standard tantalum specifications, which is advantageous in battery applications such as tire pressure monitoring systems (Fig. 1).

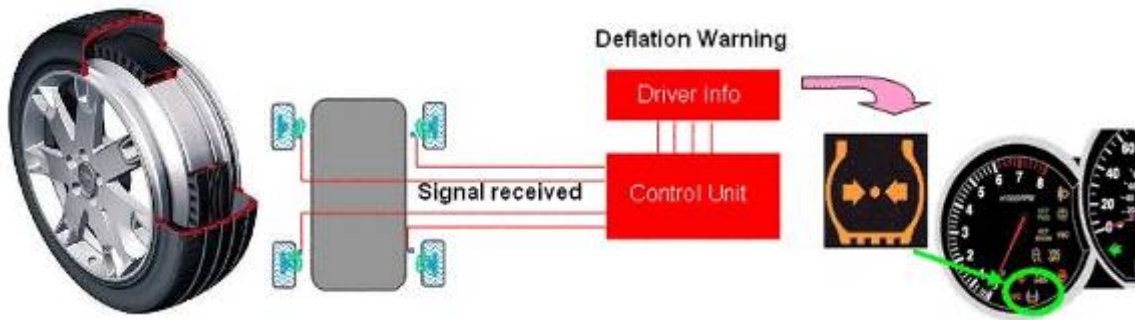

Figure 1: Tire pressure monitoring system block diagram

Standard tantalum capacitors technologies typically have a temperature range of -55 to $+125\text{degC}$ which restricts their usage to cabin entertainment and other lower temperature applications only. Some producers specifically market automotive families, which expand the possible usage of tantalum capacitors to engine compartment systems (Fig. 2, Fig. 3) which demand a continuous operating temperature of up to 150degC . However, the automotive industry requires components that work up to 175degC . With an operating temperature range of -55 to $+175\text{degC}$, AVX's THJ series meets this requirement. The category voltage, which is the maximum working voltage when actual operating temperature is considered, is 50% of rated voltage at 175degC . THJ series tantalum capacitors also offer enhanced reliability (failure rate 0.5%/1000 hours) and a higher category voltage at 125 degC (78% of rated voltage) than standard devices have (typically only 66 % of V_r). THJ capacitors are available up to $150\mu\text{F}$ and rated at up to 50V.



Figure 2: Car gasoline engine unit

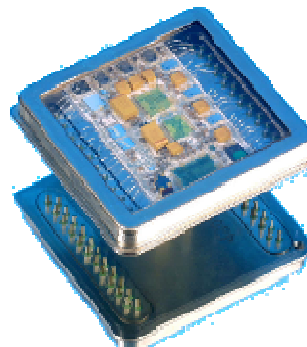

Figure 3: Emission and fuel efficiency control unit

OxiCap niobium oxide capacitors in automotive applications

NOJ and NOS low ESR OxiCap capacitors use niobium oxide powder as the main material for the anode electrode. Niobium oxide has a much higher ignition energy (200 times) and much lower burning rate than pure metal materials such as tantalum or niobium powder. This feature means that

OxiCap capacitors will not burn up to the Category voltage. Another typical failure mode is high resistance (typically 20 to 200k Ω) if the circuit is subject to an overload such as a voltage spike or high current surge. Overloads of this type can result in increased leakage current and reduced capacitance. However, an OxiCap capacitor, even if hit by a surge, will continue to provide full capacitance and functionality – at the expense of an increase in power consumption.

Series NOJ OxiCaps have a very high reliability level (failure rate 0.5%/1000 hours); low ESR NOS devices have an even lower failure rate (0.2%/1000 hours) - even more reliable than tantalum capacitors. They are suitable for applications with rail voltages of up to 8V, such as in-cabin entertainment systems, seat position modules, airbag controls etc. More, OxiCap devices offer noise-free performance and exhibit very good stability over temperature, which is preferred for absolute sound quality and a big advantage for car audio devices (Fig. 4, Fig. 5).



Figure 4: Front panel of car navigation system



Figure 5: Integrated navigation system using audio interface

In conclusion, tantalum and OxiCap capacitors are well suited to any modern automotive electronic system, whether the requirements are for enhanced reliability, wider temperature range or low leakage current.

